

**MODEL****BX**

## BX KNIFE GATE VALVE

The BX model knife gate is a bi-directional wafer type valve specifically designed for the isolation of pulverized coal burner lines on coal fired boilers during maintenance operations. The valve is dust tight which makes it suitable for other bulk handling applications, such as silo outlet valves. This valve has been designed for use in potentially explosive areas (ATEX) and it complies with DIN EN 14460 standard (Explosion Resistant Equipment). In the closed position, the valve can be used as an effective measure against flame propagation in the event of an explosion.

**Sizes:**

DN 700 to DN 1000 (smaller and larger diameters on request).

**Working pressure:**

DN 700 to DN 1000: 3 bar

**Standard flange connection:**

DIN PN 10

**Directives:**

2006/42/EC (MACHINES)

2014/68/EU (PED): Fluid: Group 1 (b), 2 (Cat. I, mod A)

2014/34/EU (ATEX)

Limits of DIR 2014/34/EU:

These valves have been classified in Device Group II and fall in the following categories:

II 1GD / 3GD c → Category 1G or 1D inside the valve/Category 3G or 3D outside the valve

II 1GD / 2GD c → Category 1G or 1D inside the valve/Category 2G or 2D outside the valve

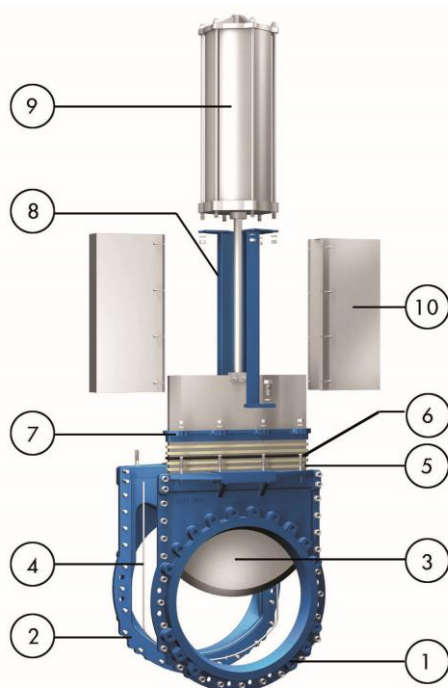
**DIN EN 14460** (DN 700-1000)

Valve housing resistance to explosion pressure and ignition disrupting resistance against St1 dust explosion in closed position:

DN 700-800: 9,6 bar

DN 900-1000: 10,5 bar

**\*IMPORTANT:** Pressure rating of the valve refers to maximum working pressure of the valve. The maximum explosion pressure exceeds many times the working pressure, so 2014/34/EU limits must always be observed

### STANDARD PARTS LIST

Part:	Material:
1- Body	Ductile Iron GJS400 /0.7040/A536 60-40-18
2- Counter body	Ductile Iron GJS400 /0.7040/A536 60-40-18
3- Gate	AISI 304 (1.4301)
4- Seal	Viton
5- Packing	PTFE Impregnated Synthetic (ST)
6- O-Ring	EPDM
7- Gland Followers	1.0044 / A570 Gr40
8- Yoke	1.0044 / A570 Gr40
9- Pneumatic Cylinder	-
10- Protection Guards	AISI 304 (1.4301)

MODEL

**BX**



## DESIGN FEATURES

### **BODY:**

Two-part bolted body, internally machined, with reinforced ribs in larger diameters for extra body strength. Gate is fully guided along the complete stroke. Wide face to face and internal design with flushing areas avoid any build up of solids that would prevent valve from closing.

### **GATE:**

Stainless steel gate, as standard. Gate is polished on both sides for a greater seal between the gate with both packing and seat. Gate is fully guided in the body allowing for bi-directional service.

### **PACKING:**

Long-life packing with a combination of multiple lines of graphite impregnated PTFE and elastomer-cover Aramid yarn, with an easily accessible packing gland to ensure a tight seal. Long-life braided packing is available in a wide range of materials.

### **ACTUATORS:**

All actuators supplied by ORBINOX are interchangeable, and supplied with a standard mounting kit for easy installation on site.

### **YOKE or ACTUATOR SUPPORT:**

EPOXY coated steel (stainless steel available on request). Compact design makes it extremely robust even under the most severe conditions.

### **EPOXY COATING:**

The epoxy coating on all ORBINOX cast iron and carbon steel valve bodies and components is electrostatically applied making the valves to be corrosion resistant with a high quality surface finish. The ORBINOX standard colour is RAL-5015 blue.

### **GATE SAFETY PROTECTION:**

ORBINOX automated valves are provided with gate guards in accordance with EU Safety Standards. The design feature prevents any objects from being caught accidentally while the gate is moving.



**MODEL****BX**

## SURFACE TREATMENTS

Valve components can be protected or coated for a longer life expectancy, depending on the application and the service conditions.

At ORBINOX we can offer treatments and coatings for the valve components to improve the properties against abrasion (Stellite, polyurethane...), corrosion (Halar, Rilsan, galvanised...) and adherence (polishing, PTFE...)

## TEMPERATURE CHART

### SEAT / SLEEVES

Material	Max.Temp.(°C)	Applications
Viton	200	General

### PACKING

Material	Max.Temp.(°C)	pH
PTFE impregn. synth. fibre (ST)	240	2-13
Graphite (GR)	600	0-14

## SEAT TYPE

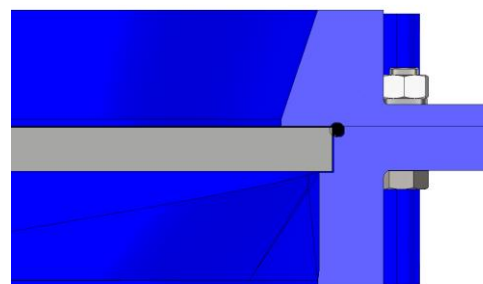
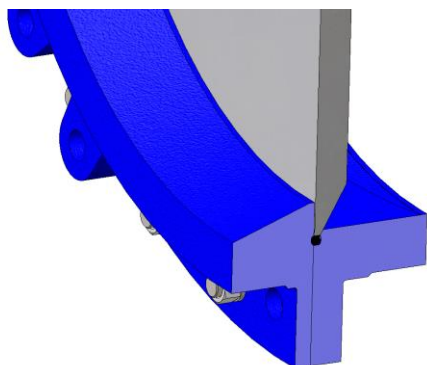

**PNEUMATIC CYLINDER**

- The standard pneumatic actuator (double acting on-off cylinder) consists of:
  - $\varnothing \leq 300$ : Aluminum barrels
  - $\varnothing \geq 350$ : Composite barrels
  - Aluminum end covers
  - Stainless Steel (AISI 304) piston rod
  - Nitrile coated steel piston
- Available in DN 700 to DN 1000
- Supply Pressure: min. 3.5 kg/cm<sup>2</sup> - max. 10 kg/cm<sup>2</sup>.  
Actuator designed with 6 kg/cm<sup>2</sup> air supply
- Options (on request):
  - Hard anodized barrel and covers
  - Stainless Steel barrel and covers
  - Over/Undersized cylinder
  - Manual override
  - Fail safe system
  - Limit switches
- Instrumentation (on request):
  - Positioners
  - Solenoid valves
  - Flow regulators
  - Air preparation units

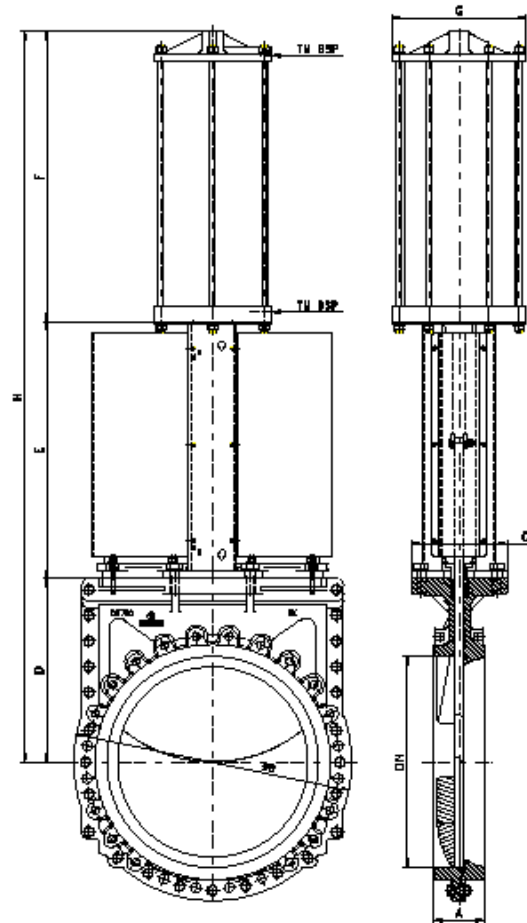

DN	A	B	C	D	E	F	G	H	Std.Cyl.	Connection
700	165	920	320	615	860	960	444	2435	C350/730	3/4" G
800	190	1040	320	700	990	1095	444	2785	C350/830	3/4" G
900	203	1125	320	820	1118	1185	515	3123	C400/930	3/4" G
1000	216	1240	335	885	1225	1285	515	3395	C400/1030	3/4" G

## GEAR (rising stem)

- Consists of:
  - Stem
  - Yoke
  - Bevel Gear Actuator with Handwheel  
(Standard Ratio 4:1)
- Available from DN 700 to DN1000
- Options:
  - Locking device
  - Extension and floor stands
  - Chainwheel
  - Non-rising stem

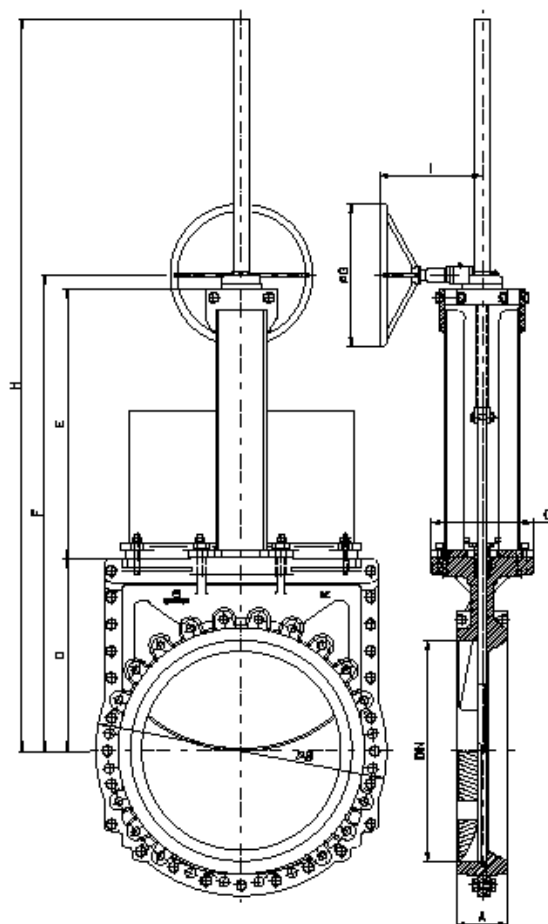



DN	A	B	C	D	E	F	G	H	GEAR BOX
700	165	920	320	615	900	1560	450	2460	RKO.3
800	190	1040	320	700	968	1770	450	2870	FL1.4
900	203	1125	320	820	1118	2040	650	3140	FL1.4
1000	216	1240	335	885	1220	2207	650	3307	FL1.4

**MODEL****BX**

## FLANGE AND BOLTING DETAILS

### EN 1092-2 PN10

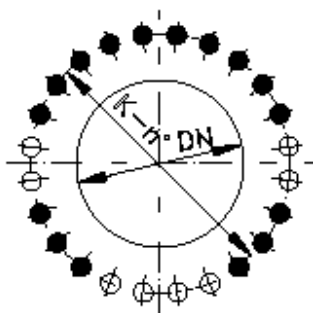

DN	K	n°	M	T	 
700	840	24	M-27	20	16 - 8
800	950	24	M-30	20	16 - 8
900	1050	28	M-30	20	20 - 8
1000	1160	28	M-33	20	20 - 8

DN 700-800

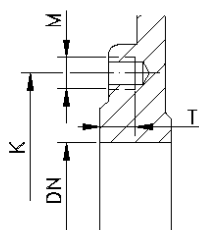
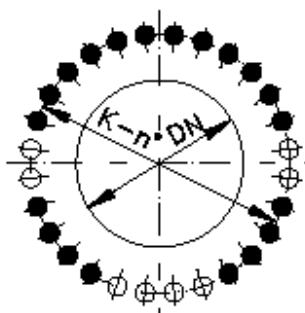

DN 900-1000



-  BLIND TAPPED HOLES
-  THROUGH HOLES